REVIEW OF ELECTRICITY SYSTEM PLANNING AND MARKET OPERATION ROLES AND STRUCTURES

FINAL REPORT

December 2011



38 Cavenagh Street DARWIN NT 0800
Postal Address GPO Box 915 DARWIN NT 0801
Email: utilities.commission@nt.gov.au
Website: www.utilicom.nt.gov.au

Table of Contents

Executive Summary	1
Regulatory and institutional arrangements for electricity supply	1
Separation of roles and responsibilities	2
System and market operation and system planning	3
Benefits of good governance	3
Assessment of existing arrangements	3
Commission's final recommendations.....	4
Implementation considerations	6
Background	8
Regulatory Framework.....	8
Power and Water Corporation.....	8
Purpose of this Review	9
Draft Report and submissions.....	10
Purpose of this Final Report	11
Regulatory and institutional arrangements for electricity supply	13
Development of electricity markets	13
System and market operation and system planning	20
Contrasting NEM and Territory governance arrangements.....	23
Effective governance arrangements for the Territory's electricity supply industry	27
Clarity about the requirements of roles and functions.....	27
Responsibility for oversight of compliance	30
Responsibility for rule-making and operation functions.....	31
Responsibility for supervisory functions and for-profit (operational) functions	33
Supporting the independence of the System Controller.....	40
Implementation considerations	42
Options for implementing the Commission's recommendations	42
Allocation of roles and functions	43
Appendix A	47
Summary of functions	47

CHAPTER 1

Executive Summary

- 1.1 The Commission has undertaken a review of the effectiveness of regulatory and institutional arrangements for electricity system and market operation in the Territory.
- 1.2 The review has been conducted according to terms of reference provided by the Treasurer in November 2009 with the objective of reviewing and reporting on the effectiveness of the system planning and market operation arrangements, including the role and structure of the system control unit of the Power and Water Corporation (PWC) and recommending a course of action to ensure that the allocation of functions to do with system planning and market operation promote efficient and reliable electricity system performance.
- 1.3 The Treasurer provided the Commission with terms of reference to:
 - assess the effectiveness of the regulatory and institutional arrangements for system and market operation in the Territory, taking into account:
 - the implications for the Territory of the distinction in the national electricity market between the power system (generation and transmission) and the distribution system;
 - the allocation of roles and responsibilities for ensuring system and market operation is safe, secure and reliable; and
 - the risk of actual or perceived conflict between the commercial and public policy roles of PWC in providing system control, network, retailer and generation services;
 - identify options for ensuring that system planning and market operation facilitate system performance that is consistent with applicable service standards and good industry practice; and
 - recommend an efficient and effective course of action and provide detailed plans for the implementation of recommendations.
- 1.4 The Commission's review takes into account all relevant economic and policy developments, including current and forecast economic conditions.
- 1.5 This Final Report sets out the Commission's recommendations for the effective allocation of responsibility for system and market operation and system planning activities in the Territory electricity supply industry and identifies implementation considerations.

Regulatory and institutional arrangements for electricity supply

- 1.6 Australian governments since the mid 1990's have progressively developed regulatory and institutional arrangements to support a competitive, market based approach to electricity generation and retail supply, and to ensure third party access to the natural monopoly network component of the supply chain. The objective is the production and
-

delivery of electricity to customers at the reliability and price levels nominated through the regulatory bargain¹.

- 1.7 The key elements of the regulatory and institutional model adopted in Australia are:
- separation of regulated network activities and contestable generation and retail activities, by ring-fencing of these activities, or legal or ownership separation of the associated businesses;
 - separation of for-profit activities from market and power system supervisory activities. These supervisory activities include market and system operation, economic regulation and compliance monitoring, and rule-making, which are managed by the independent expert authorities;
 - clear documentation in legislation of the requirements of a task or activity, including which entity is responsible for the task. The National Electricity Law and Rules establish clear 'rules' underpinning electricity supply; and
 - a robust compliance monitoring framework to provide effective oversight of the performance of tasks against the requirements of the rules.

Separation of roles and responsibilities

- 1.8 The mechanisms for separating responsibility for roles and functions adopted in Australia are either:
- ring-fencing, which involves identifying and isolating the activities, assets, costs and revenues of goods and services provided by a regulated natural monopoly business element (or an associated business element not exposed to significant competitive pressure) within a larger and integrated organisation. Ring-fencing is used in the Territory to require that activities performed by PWC's prescribed businesses (monopolies such as regulated networks and system control) and its contestable businesses (retail and generation) are undertaken at arm's length. The Ring-fencing Code also requires PWC to establish and maintain a separate set of financial accounts for its prescribed businesses;²
 - legal separation, where the regulated business element is established as a legally separate entity, but owned by a single entity (i.e. a business or government). Legal separation of retail and regulated network activities is used in the Australian Capital Territory; and
 - ownership separation, where the regulated business element is established as a separate entity in its own right, with its own management and Board. Ownership separation has occurred in Victoria and South Australia, and recently in New South Wales and Queensland.

¹ An optimisation of the price, service and risk relationship between the supplier and customers so that service performance is maintained according to customer needs, and that customers pay a fair price for that level of service. Refer Energy Networks Association, Service Standard and Regulatory Policy and National Reliability Reporting Framework, March 2007; and Essential Services Commission of South Australia, Distribution Service Standards 2010-12 Final Decision, November 2008, pages 7-8.

² Utilities Commission, Northern Territory Electricity Ring-fencing Code, January 2009, clauses 3.1 and 3.2.

-
- 1.9 There has been a trend in Australia for integrated electricity businesses with network and retail and generation activities to voluntarily adopt ownership separation of their regulated (network) and competitive (retail and generation) activities. This reflects industry and financial market recognition that the clear differences between network activities (i.e. focused on asset management and cost control) and generation/retail activities (i.e. focused on customers) warrants specific management and Board expertise.

System and market operation and system planning

- 1.10 The functions of system and market operation and system planning are regulatory and supervisory in nature, and due to the system wide implications having an important public interest dimension. The functions concern the reliability, security and operation of the power system as a whole rather than the interests of an individual electricity business.
- 1.11 System operation involves oversight of the technical parameters and the day to day operation of the power system to achieve the expected reliability, quality and safety standards. System operation is supported by the day to day management of network control and operation activities of the transmission network service provider (TNSP) and distribution network service provider (DNSP).
- 1.12 Market operation involves oversight of wholesale and retail market parameters and day-to-day operation of the wholesale exchange so that the market efficiently balances supply and demand, accounting for the transfer of consumer load between retailers, and using an optimal level of capital and resources.
- 1.13 System planning underpins system operation and market operation by identifying the electricity generation and supply infrastructure investments needed to achieve the expected price and reliability of supply levels and by providing independently determined planning information for use by industry participants, regulators and governments.

Benefits of good governance

- 1.14 The approach to allocating roles and responsibilities across the electricity supply chain (i.e. the governance arrangement) is a crucial feature of an institutional and regulatory framework that will routinely deliver reliable and cost effective electricity supply to customers.
- 1.15 Good performance is most likely to occur when the entity responsible for an activity performs that activity in the most efficient way (i.e. by making optimal operating and investment decisions). Optimal decisions are most likely to occur when the responsible entity has appropriate incentives to achieve the desired outcomes, whether by being held accountable by competitive pressure or regulatory oversight. Clear accountability allows effective measurement and management of performance.

Assessment of existing arrangements

- 1.16 The Commission considers that the Territory's regulatory and institutional arrangements are not consistent with the arrangements designed to promote good governance, in that:
- there are potential conflicts of interest between the performance of supervisory functions and for-profit electricity supply activities;
-

- performance of system operation functions may be perceived as not being conducted independently of the interests of the PWC Generation or Networks business units;
- there are difficulties in holding generators and PWC Networks accountable for the performance of functions and outcomes against stated requirements, because the operating requirements are not clearly stated and data availability is poor; and
- the regulatory arrangements do not clearly define the tasks required of businesses at each part of the electricity supply chain.

1.17 The Commission is of the view that the current regulatory and institutional framework is unlikely to encourage efficient outcomes in the Territory's electricity supply industry.

Commission's final recommendations

Requirements for good governance

1.18 The Commission recommends improvements be made to the Territory's regulatory and institutional framework for market and system operation and system planning roles and functions to adopt the characteristics and principles of good governance. The improvements should:

- provide clarity about which entity is responsible for functions and activities associated with electricity supply (through the introduction of appropriately detailed rules established by legislation);
- avoid or minimise the actual or perceived risk of a conflict of interest of a particular entity in performing an activity or function;
- hold accountable the respective entity responsible for the performance of functions and outcomes against stated requirements; and
- ensure appropriate oversight of the performance of functions and activities to confirm that the entity responsible for a task is complying with relevant legislation including monitoring of compliance with the rules by an independent and expert body.

Clarity about requirements of roles and functions

1.19 The Commission recommends that the Territory's regulatory framework be modified to provide appropriate clarity and documentation about the requirements and expectations of system and market operation and system planning roles and functions. This could involve rewriting the System Control Technical Code and the Network Connection Technical Code and there may be opportunity to incorporate these technical codes into a comprehensive Electricity Industry Code.

Responsibility for oversight of compliance

1.20 The Commission recommends the roles and responsibilities of the Commission and the System Controller be clarified, defined and documented in legislation in relation to compliance monitoring and enforcement, including:

- the System Controller (a statutory position responsible for power system control that is currently undertaken by PWC) should be responsible for monitoring and enforcing compliance by system participants with technical rules, such as those currently

contained in the System Control Technical Code and Network Connection Technical Code; and

- the Commission should be responsible for oversight of compliance by the System Controller with its obligations (including performing functions according to the rules and maintaining effective oversight of compliance by system participants).

Allocating responsibility for rule-making and operation functions

- 1.21 The Commission recommends that the Territory's regulatory framework separate responsibilities for initial rule-making and operation functions through establishing a process for amending rules or codes that gives system and market participants, the Territory Government, customers (and the Commission under specified circumstances) the ability to request the Commission to assess rule change proposals against the objectives of the regulatory framework. Proposals that meet the criteria would be adopted as a new rule or code provision.

Allocating responsibility for supervisory and for-profit functions

- 1.22 The Commission considers that adopting the National Electricity Market (NEM) approach of establishing a separate and independent system and market operator for the Territory would involve significant costs, and would leave a separate system and market operator with the difficult task of acquiring the required expertise.
- 1.23 As a pragmatic approach for allocating responsibility for supervisory and for-profit function, the Commission recommends that the System Controller be made directly accountable to the PWC Board for the performance of supervisory system and market operation and system planning activities.
- 1.24 The Commission recommends that clear lines of reporting and accountability for supervisory functions could be further developed by:
- establishing a detailed set of requirements in the regulatory framework that identify what system and market operation tasks are to be undertaken by the System Controller and what those tasks involve;
 - defining in the regulatory framework the scope of a system planning function, and clearly making the System Controller responsible for system planning; and
 - strengthening ring-fencing arrangements to require that the nature of the relationship and interactions between each of the PWC business units, including System Control, PWC Networks, PWC Generation and PWC Retail, are clearly documented and available to system participants and other relevant parties.

Financial independence of system controller

- 1.25 The Commission recommends that the System Controller be required, on an annual basis, to:
- consult with system participants on the system control services to be provided in the coming financial year, the estimated cost of those services, and the proposed system control charges required to recover that cost;
 - seek the Commission's approval for the proposed system control charges; and
 - account for expenditure of the revenues received from the system control charge in the previous financial year.
-

Implementation considerations

1.26 Implementation considerations include:

- options for implementing recommendations; and
- a proposed future allocation of roles and functions.

1.27 Implementation of the recommendations should involve development of an implementation program and project plan by an implementation group comprising representatives of industry, policy and regulatory entities. Terms of reference for the implementation group are being progressed by Northern Territory Treasury in conjunction with the Commission. It is expected that the first meeting of the implementation group will take place in February 2012.

1.28 The Commission is of the view that the recommendations can be implemented through the development of an Electricity Industry Code, providing the opportunity to:

- clearly document the requirements and expectations of system and market operation functions;
- establish responsibility for oversight of compliance with market and system operation functions, documenting the respective roles of the Commission and System Controller. This can occur through a statement of approach developed jointly by the Commission and the System Controller (in consultation with system participants), or through drafting of the Electricity Industry Code;
- establish a comprehensive rule change process that separates responsibility for rule-making and operation functions. This will require amendment to the Electricity Networks (Third Party Access) Code and the *Electricity Reform Act* (and potentially other legislation) to remove sole responsibility for administering the Network Connection Technical Code and System Control Technical Code from PWC Networks and the System Controller;
- separate responsibility for supervisory and for-profit activities by amendment of the Ring-Fencing Code, the development of new regulatory arrangements, and changes to PWC's corporate governance arrangements; and
- establish the ability of the System Controller to assess and levy a system control charge.

Allocation of roles and functions

1.29 Based on the recommendations of this Review, Table 1.1 provides a proposed allocation of key roles required for the effective management of the electricity supply chain, and the delivery of electricity according to the requirements of the regulatory bargain.

Table 1.1: Proposed allocation of key electricity sector roles

Role/functions	Responsible entity
Rule-making	Treasury and Utilities Commission, subject to a defined rule-making process.
Market operation	PWC Networks / System Controller. The limited market operation role is currently undertaken by the PWC corporate services (strategy and corporate affairs) area.

System operation/planning	System Controller.
Network operation	The System Controller could perform network operation functions under an agreement for services with PWC Networks.
Compliance monitoring	System Controller – oversight of compliance with technical codes. Utilities Commission – oversight of compliance with regulatory instruments (including compliance by System Controller).

1.30 The nature of the functions associated with the allocation of responsibilities for effective management of the electricity supply chain, including system and market operation and system planning functions is discussed in a separate Report for the Review of Electricity System Planning, Monitoring and Reporting.

CHAPTER 2

Background

- 2.1 The Commission has undertaken a review of the effectiveness of regulatory and institutional arrangements for electricity system and market operation in the Territory.
- 2.2 The objective of the review is to provide an independent and expert assessment of the effectiveness of the system planning and market operation arrangements, including the role and structure of the system control unit of PWC and recommend a course of action to ensure the allocation of functions to do with system planning and market operation promote efficient and reliable electricity system performance.

Regulatory Framework

- 2.3 The electricity supply industry in the Northern Territory is regulated through the *Electricity Reform Act*, *Electricity Networks (Third Party Access) Act*, *Utilities Commission Act* and associated legislation. This regulatory framework was introduced on 1 April 2000.
- 2.4 The regulatory framework is primarily focused on regulating the activities of electricity industry participants and customers in the Darwin-Katherine, Alice Springs and Tennant Creek power systems. Key elements of the framework are:
 - third party access to the Darwin-Katherine, Alice Springs and Tennant Creek electricity networks;
 - a staged approach to contestability with all customers becoming contestable from 1 April 2010; and
 - an independent economic regulator, the Utilities Commission, to regulate monopoly electricity services, licence market participants and enforce regulatory standards for market conduct and service performance.

Power and Water Corporation

- 2.5 The Power and Water Corporation (PWC) is the main electricity business in the Territory's electricity market systems, generating the majority of electricity used, operating the electricity networks and supplying retail services.
- 2.6 PWC is a major electricity supplier in regional and remote parts of the Territory, and is the water and sewerage service provider throughout the Territory.
- 2.7 PWC is a vertically integrated government owned corporation with generation, network and retail business units.³ The commercial relationship and transactions between each

³ This paper refers to the separate business units as PWC Retail, PWC Networks and PWC Generation.

unit is subject to oversight and regulation by the Commission.⁴ PWC is also subject to oversight by a shareholding Minister (currently the Treasurer) and a portfolio Minister (currently the Minister for Essential Services).

- 2.8 PWC has been the only electricity retailer operating in the Territory in recent years, supplying electricity to 76 603 customers at 30 June 2011.⁵
- 2.9 The Commission granted a standard electricity retail licence to QEnergy Ltd in February 2011.
- 2.10 PWC is also the main electricity generator, with about 94 per cent of generation capacity in the market systems. There are four other generators producing electricity in the Darwin-Katherine and Alice Springs systems which generate electricity under contract for PWC and do not sell directly to an electricity retailer or to customers.⁶
- 2.11 PWC Networks owns and operates the Darwin-Katherine, Alice Springs and Tennant Creek electricity networks, which comprise 709 kilometres (km) of transmission lines and 7650 km of distribution lines.⁷
- 2.12 Electricity supply in regional and remote centres of the Territory is managed through a contract for service model, with supply arrangements agreed between the service purchaser (the Territory Government) and a service provider (in most cases, PWC or subsidiary). The regional and remote centres comprise 72 communities and 82 outstations where essential services are provided through the Territory Government Indigenous Essential Services program; three mining townships, where electricity is supplied by the associated mining company; and eight remote townships.⁸

Purpose of this Review

- 2.13 In August 2009, the Commission was requested under Part 7 of the *Utilities Commission Act*, to review and report on the efficiency of system and market operation and system planning arrangements, including the role and structure of the system control unit of PWC.
- 2.14 The objective of the review is to recommend a course of action that ensures that the allocation of functions to do with system and market operation and system planning promote efficient and reliable electricity system performance.

⁴ Regulatory instruments include the licensing framework and the Northern Territory Electricity Ring-Fencing Code.

⁵ Power and Water Corporation Annual Report 2010-11.

⁶ Utilities Commission, March 2011, 2009-10 Power System Review, pages 14-15. The generators are at Pine Creek, Shoal Bay (the Darwin City Council waste facility) and Brewer Estate (in Alice Springs).

⁷ Power and Water Corporation Annual Report 2010-11.

⁸ The three mining townships are Nhulunbuy, Alyangula and Jabiru. The eight remote townships are Timber Creek, Borroloola, Daly Waters, Elliot, Newcastle Waters, Kings Canyon, Yulara and Ti-Tree.

Terms of Reference and Scope of Inquiry

- 2.15 The Commission was requested by the Treasurer to assess the effectiveness of regulatory and institutional arrangements for system and market operation in the Territory, taking into account:
- the implications for the Territory of the distinction in the NEM between the power system (generation and transmission) and the distribution system;
 - the allocation of roles and responsibilities for ensuring system and market operation is safe, secure and reliable;
 - the risk of actual or perceived conflict between the commercial and public policy roles of PWC in providing system control, network, retailer and generation services; and
 - all relevant economic and policy developments, including current and forecast economic conditions.
- 2.16 The Commission was requested by the Treasurer to identify options for ensuring that system and market operation and system planning facilitate system performance that is consistent with applicable service standards and good industry practice and recommend an efficient and effective course of action and provide plans for the implementation of that recommendation.

Draft Report and submissions

- 2.17 The Commission released a Draft Report in August 2011. The Commission received submissions from the Northern Territory Major Energy Users (NTMEU), QEnergy Limited (QEnergy), the Energy Supply Association of Australia (ESAA) and PWC.
- 2.18 NTMEU referred to comments previously made in relation to the Issues Paper and had no further comments to make.
- 2.19 QEnergy strongly supported the Commission's approach to establish a more competitive electricity market in the Territory.
- 2.20 PWC considered that the Commission had applied the NEM arrangements too literally to the Territory's circumstances, and had not fully considered the differences between PWC and the NEM, and the time, cost and effort associated with the implementation of its proposed recommendations. While not supportive of legislative change or substantive change to the regulatory institutions, PWC supported the establishment of an Electricity Industry Code as this would provide an overarching framework necessary to draw together the existing and planned elements of the Territory's electricity market and would address any overlap and ambiguity in the current roles and responsibilities.⁹
- 2.21 Similarly, ESAA noted that the general direction of the Commission's on-going and completed reviews was to more closely align the Territory arrangements with those of the NEM. While generally supportive of national regulatory frameworks, ESAA

⁹ Power and Water Corporation, September 2011, Review of Electricity System Planning and Market Operation Roles and Structures – Power and Water's Response to the Draft Report, pages 1-3.

cautioned the Commission to consider the financial impact its recommendations may have on end consumers.¹⁰

- 2.22 In response to the issues raised by PWC and ESAA, the Commission notes that the electricity supply industry is a key input to the future development of the Territory. It is vital to ensure that the industry delivers the services required by consumers at prices that reflect efficient costs. Significant reform of the industry will be required to achieve this goal, and as a consequence the Territory Government has initiated a program of reforms.
- 2.23 A key principle of the reform program is to support greater competition in the industry, and this is consistent with the Government's commitment to the National Competition Policy Agreement in 1995. Furthermore, the NEM provides an important model for electricity industry reform in the Territory. The Commission considers that the adoption of a NEM approach, where relevant, will strengthen the Territory's electricity market governance, thereby providing greater confidence to the Government that the electricity market is operating at optimal level, and to prospective new market entrants that the Territory is committed to lasting and effective competition.

Purpose of this Final Report

- 2.24 The focus of this review is the effectiveness of the governance arrangements for system operation, system planning and market operation, with effectiveness meaning that these activities fully contribute to achieving the reliability and price levels nominated through the regulatory bargain.
- 2.25 This Final Report sets out the Commission's recommendations for the allocation of responsibility for market and system operation activities in the Territory electricity supply industry and discusses implementation considerations.
- 2.26 This Final Report is structured as follows:
- Chapter Three considers the role of governance arrangements for ensuring that system and market operation facilitate desired reliability and price outcomes.
 - Chapter Four discusses governance (institutional and regulatory) arrangements for achieving nominated reliability and price outcomes.
 - Chapter Five discusses implementation considerations.
 - Appendix A provides a summary of activities involved in market operation, system operation and system planning.

Review of Electricity System Planning, Monitoring and Reporting

- 2.27 The Commission has separate terms of reference from the Treasurer to review and report on the adequacy of current performance monitoring and reporting arrangements under the *Electricity Reform Act*, and appropriate network and generation reliability standards for performance monitoring.

¹⁰ Energy Supply Association of Australia, September 2011, Review of Electricity System Planning, Monitoring and Reporting & Review of Electricity System Planning and Market Operation Roles and Structures, pages 1-2.

2.28 A Final Report for the Review of Electricity System Planning, Monitoring and Reporting has been released together with this paper. This will allow an effective and informed consideration of the allocation of the functions and responsibilities associated with system and market operation and system planning.

CHAPTER 3

Regulatory and institutional arrangements for electricity supply

Development of electricity markets

- 3.1 Australian governments since the mid 1990's have progressively developed regulatory and institutional arrangements to support a competitive, market based approach to electricity generation and retail supply, and to ensure third party access to the natural monopoly network component of the supply chain. The objective is the reliable and efficient production and delivery of electricity to customers, with competition being the most effective means to achieve that end.
- 3.2 Australia currently has three electricity markets, with each operating under their own institutions and rules (or regulatory arrangements):
- the NEM which covers the interconnected electricity systems of the eastern and southern states;
 - the Western Australian market which covers the south west interconnected system supplying Perth and surrounding regions; and
 - the Territory market which covers the non-connected systems of Darwin-Katherine, Alice Springs and Tennant Creek.
- 3.3 The institutional and regulatory framework establishing how each market is governed has developed in response to experience with the implementation of the market based approach since the 1990's and 2000's.

National Electricity Market

- 3.4 The NEM has been the focus of concerted efforts to develop an effective institutional and regulatory framework, and is now considered to represent good practice for governance of electricity markets.
- 3.5 NEM governance arrangements have developed to support the goal of economic efficiency in electricity supply by providing appropriate independence and transparency of processes, and ensuring that the entities involved in operating, planning and regulating the electricity system and market are accountable for their role in supplying electricity according to the regulatory bargain.
- 3.6 The NEM institutional and regulatory framework reflects the recommendations of two key reviews for the Council of Australian Governments (COAG) of the institutional and regulatory arrangements required for effective energy markets:
- *Towards a Truly National and Efficient Energy Market* (the Parer Report), released in December 2002; and
 - *Energy Reform – The way forward for Australia* (a report by the Energy Reform Implementation Group convened by COAG in 2006), released in January 2007.
-

- 3.7 The current governance arrangements and associated allocation of roles and responsibilities are considered settled¹¹, with:
- Australian governments, through the Ministerial Council on Energy (MCE), are responsible for setting electricity supply policy, such as the reliability standards that inform system operation and system planning activities;
 - the Australian Energy Market Operator (AEMO) operates and administers the wholesale electricity exchange and registers participants (i.e. market operation), manages generator dispatch and maintains system security (i.e. system operation), manages retail contestability processes and produces a suite of system planning information;
 - the Australian Energy Market Commission (AEMC) administers the rules for system and market operation, and assesses rule change proposals;
 - the Australian Energy Regulator (AER) oversees and enforces compliance with the rules by system participants and determines prices for electricity networks (monopoly) services; and
 - industry participants (i.e. the generators, transmission networks and distribution networks and retailers) are responsible for the day to day activities associated with producing and delivering electricity to customers.

Key features of the NEM model

- 3.8 The approach taken in Australia sees the electricity supply chain as several mutually supporting elements, with each element responsible for a defined bundle of the activities and functions required to produce and deliver electricity to customers at the reliability and price levels nominated through the regulatory bargain.
- 3.9 The key elements of the NEM model are:
- separation of regulated network activities from contestable generation and retail activities, by ring-fencing of these activities, or legal or ownership separation of the associated businesses;
 - separation of for-profit activities from market and system supervisory activities. These supervisory activities include market and system operation, economic regulation and compliance monitoring and rule-making which are managed by the independent expert authorities, respectively AEMO, AER and AEMC;
 - clear documentation in legislation of the requirements of a task or activity, including which entity is responsible for the task. The National Electricity Law and Rules establish clear 'rules' underpinning electricity supply; and
 - a robust compliance monitoring framework to provide effective oversight of the performance of tasks against the requirements of the rules.

¹¹ COAG affirmed its confidence in the energy market governance arrangements created in 2004-05 at the April 2007 COAG meeting. Refer COAG, National Reform Agenda: Competition Reform, April 2007, at http://www.coag.gov.au/coag_meeting_outcomes/2007-04-13/docs/coag_nra_competition_reforms.pdf. Recent concerns (particularly about the AER distribution network determinations) about the NEM governance arrangements are more to do with the rules than the institutions.

3.10 Figure 1 shows the allocation of roles and responsibilities that has emerged from the development of the NEM, and the application of good governance principles.

Figure 1: Allocation of roles and responsibilities across the electricity supply chain (NEM)

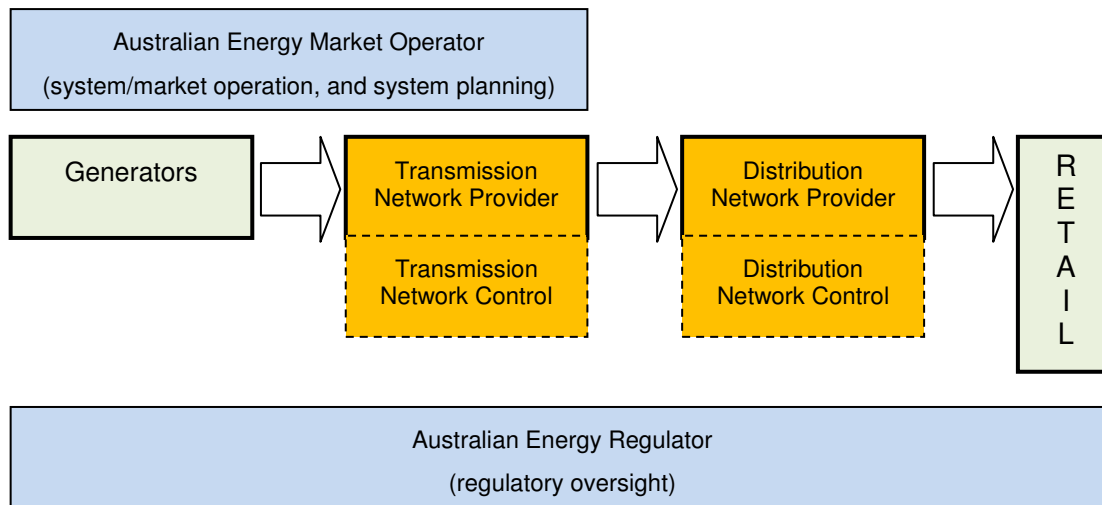

Note: Contestable activities are olive green; regulated monopoly activities are orange; supervisory activities are blue.

Principles for good governance

3.11 The allocation of responsibility for activities and functions in the NEM reflects the application of the following governance principles:¹²

- avoid actual or perceived conflicts of interest. In general this requires separating responsibilities for policy making, regulating or rule administration and service delivery;
- ensure a clear and efficient allocation of responsibility for policy functions, supervisory functions (i.e. system planning and system and market operation) and regulation;
- ensure appropriate levels of independence, with responsibility for supervisory functions not given to an entity with a profit motive; and
- ensure appropriate levels of accountability and transparency, so that the entities that are responsible for a function are held accountable for their performance and the outcomes, including through the release of information on the requirements of functions and performance.

3.12 Experience in the NEM has demonstrated that the division of responsibility for activities and functions requires clear rules that specify which entity is responsible for what task, detailing what the task involves, and establishing oversight of the performance of tasks to confirm that each entity is meeting their responsibilities according to the rules.

¹² Energy Reform Implementation Group, Energy Reform: Making Australia's Energy Markets Work Better, January 2007, page 120.

Separation of roles and responsibilities

- 3.13 In general, the NEM model allocates responsibility for a task, and the nature of the task and role, based on whether the task involves regulated network activities, supervisory activities or contestable activities. An electricity network is a natural monopoly. Supervisory activities are undertaken to support the effective administration of the market and system by coordinating the operation of the wholesale market and power system, and to supervise the interactions of system participants involved in the production and delivery of electricity to customers. Generation or retail activities are contestable.
- 3.14 The mechanisms for separating responsibility for roles and functions adopted in Australia are:¹³
- ring-fencing, which involves identifying and isolating the activities, assets, costs and revenues of goods and services provided by a regulated natural monopoly business element (or an associated business element not exposed to significant competitive pressure) within a larger and integrated organisation;¹⁴
 - legal separation, where the regulated business element is established as a legally separate entity, but owned by a single entity (i.e. a business or government). Legal separation of retail and regulated network, activities is used in the Australian Capital Territory; and
 - ownership separation, where the regulated business element is established as a separate entity in its own right, with its own management and Board. Ownership separation has occurred in Victoria and South Australia, and recently in New South Wales and Queensland with the sale of the retail activities of the government owned network and retail businesses.

Ring-fencing

- 3.15 Ring-fencing can include accounting separation (e.g. separate accounting records are kept for the regulated business) and physical separation (e.g. certain activities are carried out by staff in separate offices and/or using separate systems).
- 3.16 A key requirement of the Territory's regulatory framework is that PWC business units are "ring-fenced" to ensure that PWC does not use its vertically integrated structure and dominant market position in an anti-competitive manner.
- 3.17 The Electricity Ring-Fencing Code¹⁵ applies to PWC's Generation, Networks and Retail business units and the System Control Group (which is located in the Networks business unit). The code is intended to establish an environment where the price, quantity and quality of electricity sold to customers are not biased as a result of PWC's vertical integration. The Territory's ring-fencing requirements include:

¹³ Independent Pricing and Regulatory Tribunal, Discussion Paper and Draft Ring Fencing Guidelines, September 2000, pages 19-20

¹⁴ Pattas & Goldwater, Information gathering for ring-fencing and other regulatory purposes: Utility Regulators Forum Discussion Paper, October 1999, page 2, in Independent Pricing and Regulatory Tribunal, Discussion Paper and Draft Ring Fencing Guidelines, September 2000, page 3.

¹⁵ Utilities Commission, Electricity Ring-Fencing Code, January 2009.

- establishing and maintaining a separate set of financial accounts (prepared according to the defined accounting procedures) for the PWC Generation business, PWC Networks business and System Control Group (defined as prescribed businesses), and for the electricity business as a whole;
- allocating any costs that are shared between a prescribed business and a related contestable business (i.e. the PWC Retail business and PWC Generation) according to defined cost allocation procedures;
- ensuring that goods and services provided between prescribed and related contestable businesses are provided on terms and conditions that are at arms length; and
- ensuring that goods and services provided between prescribed and related contestable businesses are offered by the prescribed business to third parties on comparable terms to those available to the related contestable business.

3.18 The Electricity Ring-Fencing Code also requires physical separation of PWC staff engaged in marketing and sales activities for prescribed and related contestable businesses.

Legal separation

3.19 Legal separation, by establishing separate legal entities under a common owner, creates clear boundaries between the separate businesses and can reinforce accounting separation by creating a clear division between related entities. However, legally separate businesses may continue to collaborate, with there being strong commercial incentives for legally separate entities within the same organisation to continue to preference their related entities through information sharing, transfer pricing and distortions in cost allocation.

3.20 Legal separation was adopted in New South Wales and Queensland where the electricity retail and DNSP activities were undertaken by legally separate businesses owned by a common entity until the sale of the retail activities of the government owned electricity businesses. Integrated retail and network electricity businesses continue to operate in the Australian Capital Territory (ACTEWAGL).

Ownership separation

3.21 Ownership separation involves restructuring of electricity businesses to remove the incentive for businesses to engage in anti-competitive conduct by favouring related business entities. The electricity industry elsewhere in Australia has undergone structural change to establish separately owned generation, retail and networks businesses.

3.22 There has been a trend in Australia for integrated electricity businesses with network and retail and generation activities to voluntarily adopt ownership separation of their regulated (network) and competitive (retail and generation) activities. This reflects industry and financial market recognition that the clear differences between network activities (i.e. focused on asset management and cost control) and generation/retail activities (i.e. focused on customers) warrants specific management and Board expertise.

Benefits of good governance

- 3.23 Good governance, as represented by the NEM institutional and regulatory framework, establishes a clear separation of roles and responsibilities across the electricity supply chain, thereby facilitating the efficient allocation of resources.¹⁶
- 3.24 Experience in the NEM and elsewhere has demonstrated that economic efficiency in energy markets is best achieved by allowing prices to balance supply and demand and allocate resources, and by trying to ensure resources allocated to energy supply and use are 'just right'.¹⁷ This requires:¹⁸
- a clear allocation of roles and responsibilities between relevant entities, notably responsible governments, and the organisations charged with planning, operating and regulating the electricity market; and
 - making sure that the incentives (rewards and penalties) for system participants that operate in practice are designed to encourage efficient market outcomes.
- 3.25 Good governance is a crucial feature of an institutional and regulatory framework aimed at delivering a reliable and cost effective electricity supply to customers.
- 3.26 The expectation and experience is that the delivery of electricity to customers at the expected reliability and price levels is most likely to occur when the entity responsible for an activity performs that activity in the most efficient way (i.e. by making optimal investment and operating decisions), and that optimal decisions are most likely when the responsible entity has appropriate incentives (rewards and penalties) to achieve the desired outcomes, whether by being held accountable by competitive pressure or regulatory oversight. Clear accountability allows effective measurement and management of performance.

Draft recommendation – requirements for good governance

- 3.27 In the Draft Report, the Commission recommended that the Territory's regulatory and institutional framework for electricity supply ensure that responsibility for market and system operation and system planning roles and functions are allocated according to the characteristics and principles of good governance by:
- providing clarity about which entity is responsible for functions and activities associated with electricity supply. In general, this clarity would be achieved by having appropriately detailed rules established by legislation;
 - avoiding or minimising the actual or perceived risk of a conflict of interest of a particular entity in performing an activity or function;
 - holding accountable the responsible entity accountable for the performance of functions and outcomes against stated requirements; and

¹⁶ For example, see comments by the Energy Reform Implementation Group, *Energy Reform: Making Australia's Energy Markets Work Better*, January 2007, pages 44 and 51; and the Productivity Commission, *Australia's Urban Water Sector*, Draft Report, April 2011, page 258-259.

¹⁷ Energy Reform Implementation Group, *Energy Reform: Making Australia's Energy Markets Work Better*, January 2007, page 46.

¹⁸ *Ibid*, page 119.

- ensuring appropriate oversight of the performance of functions and activities to confirm that the entity responsible for a task is complying with relevant legislation. In general, this oversight would be achieved through monitoring of compliance with the rules by an independent and expert body.

Views in submissions

- 3.28 PWC's view was that the existing Territory legislation establishes clearly defined roles and functions for market participants. It accepted, however, that the amendment of the System Control Technical Code, the Network Connection Technical Code and the Network Planning Criteria, and their inclusion into a broader Electricity Industry Code would remove the overlaps and ambiguity in the roles and responsibilities. PWC brought to the Commission's attention that it had initiated reviewing the Network Connection Technical Code and the Network Planning Criteria and was planning to commence consultation. The Commission welcomes the review being undertaken.
- 3.29 PWC did not support the Commission's draft recommendation that monitoring of compliance should be transferred to an independent body. Rather, it considered it more appropriate for the Commission to fulfil this function.
- 3.30 Finally, PWC considered that the effectiveness of the institutional and regulatory arrangements needed to be tested against the efficiency with which they promote service delivery and the resulting compliance costs imposed on electricity consumers.
- 3.31 QEnergy expressed the view that there was strong potential for conflict of interest in the Territory market as a direct consequence of PWC's ownership structure, and its use of shared services and staff. QEnergy was supportive of the Commission's proposed general direction towards the adoption of a NEM-like approach.

Response to views in submissions and further analysis

- 3.32 The Commission agrees with PWC that the System Control functions relating to market and system operation and system planning could be made clearer through amendments to the System Control Technical Code and the Network Connection Technical Code. This issue is further discussed in Chapter 4 of this Final Report.
- 3.33 The Commission supports, in-principle, PWC's decision to amend and combine the Network Connection Technical Code and the Network Planning Criteria. The Commission will consult with PWC on the detail of the proposed amendments once the Code is submitted to the Commission for approval under clause 9(4) of the Electricity Networks (Third Party Access) Code.
- 3.34 The Commission considers that the establishment of an independent supervisory body to monitor compliance by the System Controller would not be feasible in the Territory's context, and in preparing its Draft Report, the expectation was that the Commission would perform this role.
- 3.35 The Commission acknowledges that compliance costs need to be considered when assessing the effectiveness of the institutional and regulatory arrangements. However, experience in other jurisdictions has shown that the initial costs of setting up new systems are outweighed by the efficiencies gained as a result of adopting more efficient practices and the emergence of more robust competition.

Final recommendation

3.36 The Commission does not propose to make further changes to its recommendations relating to the requirements for good governance.

System and market operation and system planning

3.37 The functions of market operation, system operation and system planning are regulatory and supervisory in nature, and due to the system wide implications have an important public interest dimension. The functions concern the reliability, security and operation of the power system as a whole rather than the interests of an individual electricity business:

- market operation involves oversight of wholesale and retail market parameters and day to day operation of the wholesale exchange (i.e. actions and interactions of buyers and sellers of wholesale electricity) so that the market efficiently balances supply and demand, accounting for the transfer of customer load between retailers, using an optimal level of capital and resources;
- system operation involves oversight of the technical parameters and the day to day operation of the power system to achieve the expected reliability, quality and safety standards (i.e. the system routinely operates within the technical envelope). System operation is supported by the day to day management of network control and operation activities of the TNSP and DNSP; and
- system planning, which underpins system operation and market operation by identifying the electricity generation and supply infrastructure investments needed to achieve the expected price and reliability of supply levels and by providing independently determined planning information for use by industry participants, regulators and governments.

3.38 The effective performance of these activities is essential to produce and deliver electricity to customers at the reliability and price levels nominated through the regulatory bargain. For example:

- generation dispatch decisions (market operation) determine the amount of capacity online and available at a point of time. An optimal decision will match capacity with current and expected demand, thereby minimising wholesale costs while maximising reliability. A sub-optimal decision could increase costs and reduce reliability;
 - monitoring compliance by generators with their agreed operating and performance standards (system operation) provides assurance that a generator can and will perform as expected. Poor knowledge of compliance could lead to a generator being dispatched without having the technical capability. This could cause or exacerbate reliability problems;
 - the analysis, investigation and reporting on the cause and response to all system incidents (system operation) provides crucial system health information that can highlight improvements to operating practices or identify investment needs. A less than comprehensive approach to investigating incidents could miss the opportunity to improve operating practices or miss the early warning signals of a catastrophic failure; and
-

- security and adequacy analysis (system operation and system planning) is necessary to understand whether the power system is able to meet security and reliability standards. Rigorous analysis should provide forewarning of potential network or generation constraints to allow optimal planning and investment decisions.

Responsibility for system and market operation and system planning

Arrangement in the NEM

- 3.39 The model adopted in the NEM gives responsibility for system and market operation and system planning to independent bodies acting under charters¹⁹ that require them to act to deliver market outcomes consistent with government policy intentions. This is consistent with the conclusion reached by the Energy Reform Implementation Group (and confirmed by COAG) about appropriate governance arrangements for electricity markets.²⁰
- 3.40 System operation, market operation and system planning are the responsibility of AEMO, which operates according to clear rules administered by the AEMC, with input from industry participants (e.g. operating data). The AER has oversight of the performance of system and market operation activities of AEMO and system participants (i.e. generators and TNSPs).

Arrangements in the Territory

- 3.41 The model in place in the Territory gives responsibility for system and market operation to the System Controller (a position or entity established by the *Electricity Reform Act*). The system planning function is not explicitly established and responsibility for system planning is not explicitly allocated to a particular entity.
- 3.42 PWC is the electricity entity licensed to perform system control over the Territory power systems.²¹ System control functions are performed by the System Control Group within the PWC Networks business unit. The Group Manager System Control is the System Controller.²² The System Controller is a statutory position responsible for:²³
- ...the function of monitoring and controlling the operation of the power system with a view to ensuring that the system operates reliably, safely and securely in accordance*

¹⁹ The charters of AEMO, AEMC and AER are defined by governments through the MCE in the National Electricity Law and Rules, *Australian Energy Market Commission Establishment Act* (South Australia) and *Competition and Consumer Act* (Commonwealth) Part IIIAA.

²⁰ Energy Reform Implementation Group, *Energy Reform: Making Australia's Energy Markets Work Better*, January 2007, figure 11, page 123.

²¹ Refer to the *Electricity Reform Act*, s38 (Functions and powers of system controller); s30 (Licence conditions – licence authorising system control) and the System Control Licence issued to Power and Water Corporation, [http://www.nt.gov.au/ntt/utilicom/s_docs/280211-System%20Control%20Licence-compliance%20process%20\(with%20seal\).pdf](http://www.nt.gov.au/ntt/utilicom/s_docs/280211-System%20Control%20Licence-compliance%20process%20(with%20seal).pdf).

²² As required by the PWC System Control Licence, PWC advised the Commission in August 2010 that the Manager System Control was the System Controller (effective from 13 September 2010).

²³ *Electricity Reform Act*, s38(1).

*with a technical code prepared by the system controller and approved by the Utilities Commission.*²⁴

- 3.43 System control functions include system operation, with the activities and responsibilities associated with system operation detailed in the System Control Technical Code and supporting guideline documents developed by the System Controller (e.g. Secure System Guideline).²⁵
- 3.44 The Territory's wholesale electricity market operates on a bilateral contracting basis, where generators and retailers negotiate the price of wholesale electricity. There is no wholesale reference price, such as the spot prices published for the NEM, which means there is limited public information available on the cost or price of wholesale electricity. Because the wholesale exchange mechanism involves a commercial negotiation between parties, and there has been no retail market, the Territory has an undeveloped market operation function relative to the NEM, without the retail and wholesale market systems and processes associated with a contestable and competitive electricity market.
- 3.45 The System Control Group, PWC Networks and PWC Generation business units all undertake system planning related activities in the course of their day to day business (e.g. demand forecasting). The Commission relies on the outcomes of these planning activities in preparing the annual power system review, which is the sole public source of system planning information for the Territory.²⁶
- 3.46 Responsibility for system and market operation in the Territory are allocated as follows:
- System Controller has a statutory responsibility for system operation and monitoring and controlling the power system to ensure the system operates reliably, safely and securely in accordance with the System Control Technical Code;
 - System Controller is responsible for some market operation functions, including management of ancillary services and administration of the out of balance energy arrangements (a wholesale exchange related activity);²⁷
 - Commission registers participants in the Territory market through the licensing framework (market operation);²⁸
 - System Controller is responsible for oversight of compliance by system participants with the technical codes. The Commission has a general responsibility for oversight of compliance by licence holders with the regulatory framework, including compliance by the System Controller and market participants; and

²⁴ It can be noted that, in addition to its statutory system and market supervisory role, the System Controller performs network operation functions for the PWC Networks business unit.

²⁵ System Control Technical Code (v3), May 2010, [http://www.nt.gov.au/ntt/utilicom/s_docs/SCTC-V3.0%20FINAL%20\(UC%20approved\).pdf](http://www.nt.gov.au/ntt/utilicom/s_docs/SCTC-V3.0%20FINAL%20(UC%20approved).pdf).

²⁶ *Electricity Reform Act*, s45.

²⁷ Refer *Electricity Reform Act* s82-87A (Charges for out of balance energy services).

²⁸ *Electricity Reform Act*, ss14-17

- generators and the PWC Networks business unit are responsible for producing and delivering electricity to customers according to the rules. This includes operation of electricity infrastructure, such as the operation of the transmission and distribution networks according to the requirements of the technical codes.

3.47 System planning functions are not explicitly allocated to a particular entity. However, the Commission is required to produce the annual power system review²⁹ which is the main source of publicly available system planning information.

Contrasting NEM and Territory governance arrangements

3.48 The Territory's regulatory and institutional framework was put in place in 2000 in response to the Territory Government's decision to become a signatory to the National Competition Policy.³⁰ The current governance arrangements and associated allocation of roles and responsibilities are as follows:

- regulated network activities and contestable activities are separated by ring-fencing, with the Territory Ring-Fencing Code requiring PWC Networks and PWC Generation business units and the System Control function to keep separate accounts, follow defined accounting and cost allocation procedures and physically separate marketing and sales staff;
- supervisory activities are primarily managed by PWC, through the ring-fenced PWC Networks business System Control Group. The System Controller is responsible for system operation. Market operation functions required for retail contestability are currently managed by the PWC Strategy and Corporate Affairs Group. The Commission is responsible for oversight of compliance with regulatory obligations and publication of some planning information through the power system review;
- the rules and requirements for system and market operation are documented in the Network Connection Technical Code and System Control Technical Code. These documents are quite high level and less specific about the requirements of functions than is the case in the NEM; and
- compliance monitoring is the responsibility of the System Controller and the Commission. The System Controller is responsible for monitoring and requiring compliance with the technical codes. The Commission has a general responsibility for monitoring and enforcing compliance with regulatory instruments.

²⁹ *Electricity Reform Act*, s45.

³⁰ The National Competition Policy (NCP) agreements commit Commonwealth, State and Territory governments to a range of microeconomic reforms such as: the review of all laws that restrict competition and introduction of competitive neutrality to ensure that publicly-owned businesses compete with privately-owned businesses on an equal basis; structural reform of public monopolies to facilitate competition; and development of a National Access Regime.

3.49 Figure 2 shows the allocation of roles and responsibilities for the Territory.

Figure 2: Allocation of roles and responsibilities across the electricity supply chain (NT)

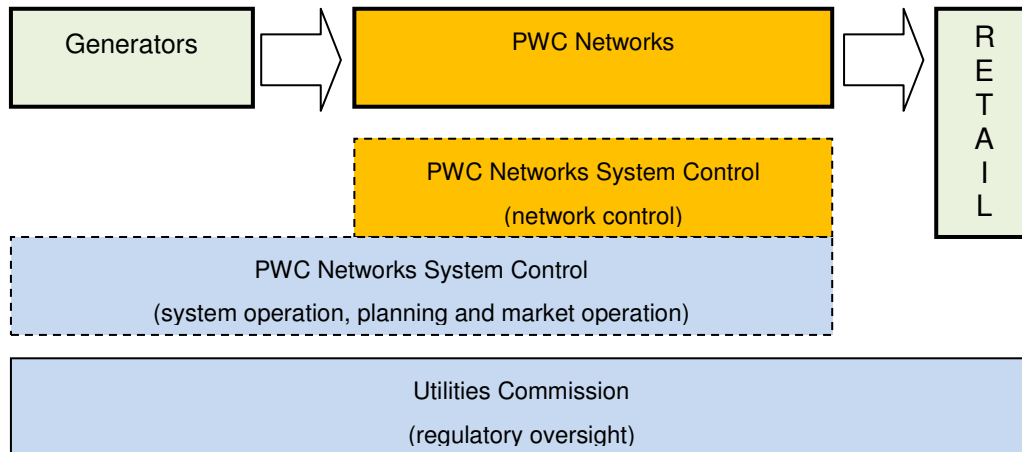

Note: Contestable activities are olive green; regulated monopoly activities are orange; and supervisory activities are light blue.

Assessment of existing arrangements

3.50 Based on 10 years' experience, the Commission considers that the Territory's regulatory and institutional arrangements are not consistent with the arrangements which promote good governance, in that:

- potential conflicts of interest between the performance of supervisory functions and for-profit electricity supply activities exist and are not well managed;
- there are difficulties in holding generators and PWC Networks accountable for the performance of functions and outcomes against stated requirements, because the operating requirements are not clearly stated and data availability is poor; and
- relative to good industry practice, the regulatory arrangements do not clearly define the tasks required of businesses at each part of the electricity supply chain.

3.51 This assessment is based on concerns identified through the series of reviews undertaken by the Commission as part of the Territory Government priority work program, the 2008-09 and 2009-10 power system reviews and compliance and reliability performance monitoring activities. Examples of these concerns, and the risks associated with the current arrangements are:

- there is the potential that power system incident analysis and investigation may not be sufficiently thorough, or can be perceived as such, due to a possibility that the System Controller may be influenced by the interests of the related PWC Generation or Networks business units. Irrespective of actual practice, having the System Controller reporting to the General Manager PWC Networks on public interest system operation matters creates the perception of a conflict of interest where the incident investigation may reflect poorly on PWC Network operations;
- the System Controller may not give appropriate attention to the technical compliance and operational risks of the related PWC Generation or Networks business units, or may not have sufficient authority within PWC to critically examine the level of compliance and the potential risks, or require change;

- system planning practice and outcomes may be influenced by system or network operation priorities, potentially resulting in sub-optimal planning decisions and, eventually, sub-optimal reliability performance or higher electricity costs; and
- uncertainty about the responsibilities and accountabilities of the System Controller, PWC Networks, PWC Generation and the Commission, causing uncertainty about priorities and responsibilities, poor decision making and eventually sub-optimal reliability performance or higher electricity costs.

3.52 The Commission considers that the existing governance arrangements contribute to the risk of sub-optimal operational and planning outcomes that are not in the long term interest of customers, including by contributing to reduced reliability performance outcomes and higher electricity costs. For example:

- the deteriorated condition of generation assets that has been identified through the assessment of asset condition since early 2010 would probably have been detected sooner if the infrastructure operators had been effectively held accountable against their regulatory obligations through appropriate compliance monitoring by the System Controller (as system operator); and
- system planning does not appear to have been sufficiently rigorous to provide timely and authoritative guidance about optimal capital and maintenance investment decisions. Recent new generation investments have been initiated due to the poor condition of existing assets, as well as a greater than forecast (organic) demand growth. There is the potential that the timing and location of the new generation infrastructure is sub-optimal.

System and network management

3.53 The Territory's governance arrangements require the functional separation of regulated network activities, supervisory activities and contestable activities, relying on ring-fencing to manage the risks associated with related parties obtaining a commercial advantage by dealing with each other on a preferred basis (and to the potential detriment of customers).

3.54 Ring-fencing can be an effective tool for providing assurance that regulated network or supervisory activities are performed so as to not give preference to related parties to the responsible entity.

3.55 The NEM comprises a number of separately owned transmission and distribution networks. Effective coordination and operation of these interconnected networks and the power system is the responsibility of the network businesses, AEMO (as system operator) and AER (oversight of regulatory and technical compliance).

3.56 In contrast, the Territory has a single network operator. This simplifies the coordination and operation of the network, and makes it possible to contain the system operation function within the regulated network business.

3.57 An equivalent to the Territory situation is Western Power, the network operator for the Western Australian south west interconnected system (SWIS). The System Management function for the SWIS is undertaken by a segregated business unit within Western Power, with roles and functions specified in legislation. System Management is responsible for the operation and control of generator facilities, transmission and distribution networks and demand side management. The overarching role of System

Management is to maintain safe, secure and reliable operation of the power system in accordance with the rules set by the regulatory framework.³¹

- 3.58 This indicates is that governance arrangements for the system management functions (comprising coordination of generation, transmission and distribution network operations) may be allocated to the regulated network element where there is only one network business if there is appropriate separation between the regulated network business (incorporating the system management function) and related contestable businesses.

Comprehensive rules

- 3.59 Experience in the NEM has demonstrated that the division of responsibility for activities and functions requires clear rules that specify which entity is responsible for what task, detailing what the task involves, and establishing oversight of the performance of tasks to confirm that each entity is meeting their responsibilities according to the rules.
- 3.60 The Commission considers that the Territory's regulatory framework requires a more comprehensive set of rules to detail how obligations are to be performed and what entity is expected to perform the associated tasks. Well defined regulatory requirements enhance accountability and transparency by defining the nature of the task and the expected outcomes.
- 3.61 Well defined rules with clearly defined expectations will assist oversight of compliance with obligations to confirm that each entity is meeting their responsibilities according to the rules, including through the release of information on the requirements of functions and performance.

³¹ Refer Western Power website, http://electric.westernpower.com.au/mainContent/workingWithPower/systemManagement/System_management.html, viewed 22 June 2011.

CHAPTER 4

Effective governance arrangements for the Territory's electricity supply industry

- 4.1 The Territory's regulatory framework does not establish effective governance arrangements for system and market operation and system planning. The Commission's view is that the Territory's regulatory and institutional arrangements should:
- clearly document the obligations of entities involved in system and market operation and system planning to provide certainty about the requirements of a function and the responsibilities of each entity;
 - clearly and appropriately allocate responsibility for system and market operation functions so that entities can be held accountable for the performance of their functions and to avoid or minimise conflicts of interest between for-profit and supervisory activities; and
 - support the necessary independence of action associated with the effective performance of system and market operation and system planning activities.
- 4.2 The Commission's recommendations in this Final Report are considered to support the test of effectiveness by:
- ensuring that the rules for market and system operation are clear and explicit, thereby clearly stating the task, and what the responsible entity is expected to achieve (accountability);
 - providing a clear set of rules against which the performance of the responsible entity can be monitored (transparency);
 - minimising the prospect of a conflict of interest by clearly identifying the compliance monitoring and enforcement roles and functions, and by separating responsibility for rule-making and operation functions;
 - clearly stating the task, and what the Commission and System Controller as the responsible entities are expected to achieve (accountability); and
 - giving the System Controller a measure of financial independence in the performance of system and market operation functions (independence).

Clarity about the requirements of roles and functions

- 4.3 Developing industry practice is to clearly set out the requirements of a particular function, thereby providing a comprehensive and certain set of rules to be followed by the responsible electricity entity. The National Electricity Rules (version 46 at 10 November 2011) are a dynamic 'living' set of arrangements that extend to 1200 plus pages, and clearly prescribe which entity is responsible for what task, and the requirements of the task.
- 4.4 The Territory's regulatory framework, which has changed very little in a decade of operation, takes a 'light-handed' regulatory approach by providing high level principles
-

and expectations to guide the activities and conduct of retailers, generators, networks and customers. Effectively the expectation when the framework was being developed was that commercial imperatives and competitive pressures would encourage entities to negotiate efficient outcomes. As a consequence, the Territory regulatory framework leaves much of the detail for interactions between entities (i.e. their respective roles and responsibilities) to be worked out through commercial and contractual processes. In contrast, the terms and conditions for the relationships between the retailer, DNSP and customer elsewhere in Australia are detailed in legislation, effectively creating a default contract setting out the basic standards for supply of network and retail services.³²

- 4.5 The light-handed regulatory approach and static nature of the arrangements has contributed to the risks associated with the Territory's system and market operation and system planning arrangements. Poorly defined tasks without clear allocation of responsibility gives market and system participants the opportunity to interpret a function in a way that is advantageous to their commercial interests, even if this is to the detriment of effective system or market operation, and inconsistent with the intentions of the regulatory framework (and the long term interests of customers). Further, not having clear rules makes it difficult to hold any entity responsible for market outcomes.
- 4.6 The System Control Technical Code establishes a reliability standard of either N or N-1 on various sections of the network.³³ This is an open ended statement that does not highlight the criteria on which a decision is made to invest at either standard. Importantly it would appear to be more of an investment standard than an operational philosophy. The network standard is also open ended, requiring PWC Networks to plan and design its networks so that system average outage duration time is minimised.³⁴
- 4.7 The network configuration is managed in part in the System Control Technical Code,³⁵ but one operating philosophy which ideally (given industry practice) should be outlined is how requests to take network assets out of service are assessed, and under what circumstances a planned outage would be deferred.
- 4.8 Similarly, the System Control Technical Code establishes a reliability standard for generation, but does not clearly express how the standard should be applied. The smaller a power system, the more critical is the management of reserves and the maintenance of security. Security comes at significant operating expense and so the level of security to be maintained by the system operator needs to be clear.
- 4.9 The lack of clarity about standards means it is difficult to hold the system operator (i.e. the System Controller) accountable for achieving a given standard.

³² Refer the Queensland Electricity Industry Code; the *National Energy Retail Law (South Australia) Act 2011* (to be commenced).

³³ System Control Technical Code, version 3, May 2010, s3.2.1

³⁴ Network Planning Criteria, version 2, April 2003, s.3.1.1

³⁵ System Control Technical Code, version 3, May 2010, ss3.3.2(b)(c) and 3.3.3

Draft recommendation – clarity about requirements of roles and functions

- 4.10 In the Draft Report, the Commission recommended that the Territory’s regulatory framework be modified to provide appropriate clarity about the requirements and expectations of system and market operation and system planning roles and functions through:
- a comprehensive assessment of the purpose and expectations versus the documented requirements of the roles and functions established through the regulatory framework, and particularly the System Control Technical Code and Network Connection Technical Code. The objective is to properly document the requirements of a function so as to avoid any doubt about what the function involves, and the expectations of the entity responsible for that function; and
 - where necessary, revise the regulatory framework to clearly document the requirements of all roles and functions. As this would involve rewriting the technical codes, the opportunity exists to incorporate these technical codes into a comprehensive Electricity Industry Code.

Views in submissions

- 4.11 PWC’s view was that the legislative requirements specifying the existing System Control Technical Code, the Network Connection Technical Code and the Network Planning Criteria did not require amendment and that system and market operation and system planning roles were already clearly defined.
- 4.12 PWC re-iterated its initiative to revise the Network Connection Technical Code and the Network Planning Criteria, and its support for the consolidation of the technical codes and the Network Planning Criteria into an Electricity Industry Code. PWC considered that this should address overlaps and ambiguity about the roles and responsibilities.

Response to views in submissions and further analysis

- 4.13 The Commission is not convinced that the legislative arrangements in the Territory, as they currently stand, define system and market operations and system planning roles adequately. Lack of clarity as to the roles of market participants, requirements and standards set out in the Territory framework makes it difficult to hold anyone accountable.
- 4.14 The Commission agrees with PWC that the development of an Electricity Industry Code should provide the opportunity to review and clarify the roles and functions of the electricity market participants in the Territory.
- 4.15 While acknowledging PWC’s review of the Network Connection Technical Code and the Network Planning Criteria, the Commission will form a view on the adequacy of the amendments once the proposed revised Code is submitted to the Commission for approval.

Final recommendation

- 4.16 The Commission does not propose to make further changes to its recommendations about better defining the responsibility for oversight of compliance. The Commission notes that the matters raised in this review might be addressed in the development of an Electricity Industry Code.
-

Responsibility for oversight of compliance

- 4.17 Regulatory obligations and rules need to be followed. Otherwise the expected outcome will not be achieved.³⁶ Thus, non-compliance with the technical parameters for the power system will lead to sub-optimal reliability outcomes – customers will experience more power outages (and potentially higher prices) than is acceptable given the standards nominated through the regulatory bargain.
- 4.18 Compliance monitoring and enforcement processes are an essential requirement for encouraging compliance by providing the electricity entity with incentives (i.e. rewards and penalties) for complying with the rules. In particular, compliance processes are used to confirm that the entity performs their tasks as required by the rules.
- 4.19 The Commission and System Controller are responsible for oversight and enforcement of compliance, but the Territory's regulatory framework does not establish clear boundaries between their respective compliance responsibilities.
- 4.20 The System Controller has a general responsibility for monitoring compliance through its statutory obligation to monitor and oversee the operation of the power system, plus specific responsibility for monitoring and enforcing compliance by system participants with the System Control Technical Code.³⁷ The Commission has a general responsibility for monitoring and enforcing compliance with the regulatory framework.
- 4.21 The Commission considers that a coordinated approach to compliance where the role and function of each entity is clearly documented or understood is essential for effective compliance monitoring and enforcement. Inconsistent or conflicting compliance priorities would make the compliance task more difficult for system participants and lead to higher regulatory costs through misallocation of resources.
- 4.22 The Commission takes the view that responsibility for compliance is implied through the regulatory framework:
- the System Controller is responsible for oversight of compliance by system participants with their obligations under the System Control Technical Code; and
 - the Commission is responsible for oversight of compliance by the System Controller with its obligations, firstly that the System Controller performs its functions according to the rules and secondly that the System Controller is maintaining effective oversight of compliance by system participants.

Draft recommendation – responsibility for oversight of compliance

- 4.23 In the Draft Report, the Commission recommended that responsibility for oversight of compliance with market and system operation and system planning requirements be allocated as follows:
- the System Controller should be responsible for monitoring and enforcing compliance by system participants with technical rules, such as those currently contained in the System Control Technical Code and Network Connection Technical Code; and

³⁶ This statement presumes that the rules are 'right'.

³⁷ System Control Technical Code, version 3, May 2010, s1.1

- the Commission should be responsible for oversight of compliance by the System Controller with its obligations, firstly that the System Controller performs its functions according to the rules and secondly that the System Controller is maintaining effective oversight of compliance by system participants.

Views in submissions

- 4.24 PWC recognised that the System Controller is the appropriate entity to monitor and enforce compliance with the technical rules. PWC brought to the Commission's attention that the System Controller had increased its engineering capability to better manage its monitoring activities. PWC also highlighted the significant investment it had made following the recently added licence obligation to implement a compliance framework in line with the standards set out in the AS3806.
- 4.25 PWC expressed its preference for the Commission overseeing the System Controller's compliance with its obligations.
- 4.26 QEnergy was of the view that the System Controller was not independent of PWC. The Commission would need to strongly concern itself with the strength of the relationships within PWC and the signals this sent to investors. QEnergy supported the Commission's proposal to have an oversight of compliance by the System Controller.

Response to views in submissions and further analysis

- 4.27 The Commission acknowledges PWC's significant efforts in strengthening the role of the System Controller and developing a culture of compliance.
- 4.28 The Commission acknowledges that compliance of the System Controller can be monitored by the Commission through the general compliance provisions set out in the System Control licence. However, the Commission is of the view that the overseeing functions of the System Controller's compliance with its obligations should be specifically defined at a policy level and explicitly stated and documented in the legislation. This would result in a more effective regulatory framework.

Final recommendation

- 4.29 The Commission does not propose to make further changes to its recommendations about clarifying the requirements of roles and functions.

Responsibility for rule-making and operation functions

- 4.30 An entity that has (even some) responsibility for rule-making, together with responsibility for system or market operation decisions faces a potential conflict of interest – there is the potential that an entity with dual rule-making and operation responsibilities may make rules that favour themselves, by for example, setting less onerous standards than warranted given industry practice, or by not setting or changing standards at all.
- 4.31 The System Control Technical Code and Network Connection Technical Code give the System Controller and PWC Networks a dual responsibility for rule-making and operations. Although neither the System Controller nor PWC Networks have the final

say over rule changes, they have significant control over when rule changes are requested.³⁸

- 4.32 The dual responsibility presents a clear conflict of interest between the management of the operational priorities (a commercial activity) and the public interest concerns of rule-making. The Commission notes that there have been two revisions to the System Control Technical Code initiated by the System Controller since 2002³⁹, while the Network Connection Technical Code has not been amended since being approved by the Commission in 2003.⁴⁰
- 4.33 The AEMC is responsible for rule-making in the NEM, involving accepting rule change proposals from system and market participants, assessing the proposal against the requirements of the National Electricity Law and how it contributes to achieving the National Electricity Objective, and then making/not making the rule.⁴¹
- 4.34 A primary purpose of creating the AEMC was to separate responsibility for rule-making and operations. A similar institutional model is not feasible for the Territory due to the small market size, but a pragmatic alternative is to remove sole responsibility for initiating rule changes from the System Controller and PWC Networks by establishing a clear rule change process.

Draft recommendation – allocating responsibility for rule-making and operation functions

- 4.35 In the Draft Report, the Commission recommended that the Territory's regulatory framework separate responsibilities for rule-making and operation functions through establishing a process for amending rules or code provisions that gives system and market participants, the Territory Government, customers (and the Commission under specified circumstances) the ability to request the Commission to assess rule change proposals against the objectives of the regulatory framework. Proposals that meet the criteria would be adopted as a new rule or code provision.
- 4.36 This proposal would be best given effect if all rules and codes are incorporated into a comprehensive Electricity Industry Code and were subject to the same rule change process.

Views in submissions

- 4.37 PWC did not support the idea of establishing a new independent organisation to monitor compliance with the rules. PWC saw this function as being more closely related to the Commission's existing role of monitoring and enforcing regulatory compliance.
- 4.38 PWC's view was that the existing governance arrangements do not need to be changed at this stage.

³⁸ PWC Networks is the only entity able to request a variation to the Network Connection Technical Code, and the System Controller has primary responsibility for requesting a variation to the System Control Technical Code. The Commission has the ability through the PWC System Control Licence to direct the System Controller to amend to the System Control Technical Code.

³⁹ Version 2 was approved in June 2008; version 3 was approved in May 2010.

⁴⁰ Version 2 was approved in August 2003.

⁴¹ AEMC, National Electricity Rules –Guidelines: Guidelines for proponents preparing a rule change proposal, July 2009, <http://www.aemc.gov.au/Media/docs/Guidelines%20for%20proponents-9453028c-a1df-42c4-a3bf-c29f42504e1e-2.PDF>.

-
- 4.39 PWC proposed that, should a change to the market governance arrangements be considered necessary, the rule development and approval function be divested to an agency other than the Commission, such as the Northern Territory Treasury or the AEMC, and the Commission retain its compliance monitoring and enforcement activities.
- 4.40 PWC appeared to be supportive of the proposed process for participant-initiative rule changes. Such a proposal could be incorporated into the development of an Electricity Industry Code and would not require legislative change.
- 4.41 QEnergy stated that the divestment of rule-making to a non-government and non-rule implementing body had been a beneficial change to the NEM. QEnergy was of the view that the Commission's proposal would increase confidence among private sector national players such as QEnergy.
- 4.42 QEnergy was supportive of the Commission's recommendation.

Response to views in submissions and further analysis

- 4.43 The Commission supports the development of a single comprehensive Electricity Industry Code as it would enable effective separation of rule-making and operation functions.
- 4.44 The Commission agrees with PWC's interpretation of the proposed governance arrangements with the policy direction allocated to the Territory Government, initial rule development function given to the Northern Territory Treasury, and rule administration, on-going rule amendment and compliance allocated to the Commission.

Final recommendation

- 4.45 The Commission does not propose to make further changes to its recommendations about allocating responsibility for rule-making and operation functions.

Responsibility for supervisory functions and for-profit (operational) functions

- 4.46 Good governance practice involves the market and system operation and planning related supervisory activities being undertaken by an independent and specialist entity, such as AEMO in the NEM.
- 4.47 The corporate structure adopted by PWC incorporates the System Control (system management) function in the PWC Networks business unit, with interactions between the System Controller and other units of PWC subject to ring-fencing arrangements. The Commission is advised by PWC that service level agreements exist between the PWC Networks business unit and Retail business unit, and between the PWC Networks System Control Group and PWC Networks, Generation and Retail business units. These agreements define, at a high level, the relationship between each area.
- 4.48 Locating supervisory (market operation, system operation, planning) functions within a regulated network business is not inconsistent with good governance practice where:
- the electricity supply chain involves a single network operator, as is the case in the Western Australian SWIS and the Territory;
 - the requirements of the supervisory function are clearly specified, allowing oversight of the performance of the system management task and outcomes. This paper discusses the need for clear and explicit rules; and
-

- there is appropriate separation or ring-fencing between the regulated network and supervisory activities, and with related entities.

Functional separation

4.49 Figure three shows a PWC structure where there is functional separation of regulated network and supervisory activities, and of these activities from contestable related generation and retail activities. This is the present structure.

Figure 3: Structure with functional separation of regulated network and supervisory activities

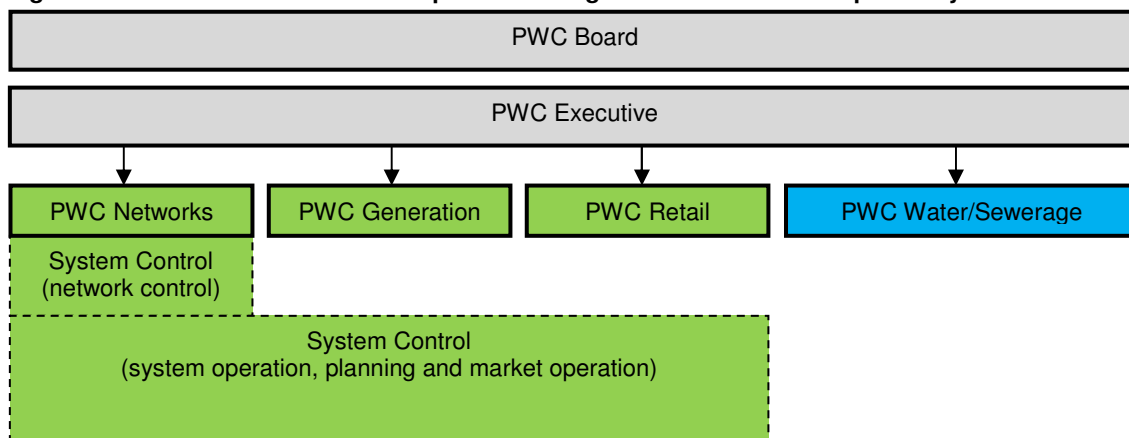

- 4.50 The effectiveness of structural separation can be measured by the degree of confidence of system participants (i.e. competing generators and retailers), customers and the Commission that the System Control supervisory functions are conducted independently of related PWC business units and activities.
- 4.51 The absence of competing generators has made for limited questioning of the performance of System Control supervisory functions. However, the Commission's experience since 2009 is that there is a credible risk that System Control supervisory functions may be influenced by the interest of related PWC business units and not performed independently. A perception that system and market operation are not independent represents a barrier to entry by potentially deterring investment by competing generators.
- 4.52 Strengthening the ring-fencing arrangements could occur by clearly specifying the nature of all supervisory activities and the nature of the relationship and interactions between the System Control Group (for supervisory activities) and the PWC Networks, PWC Generation and PWC Retail business units. Details of these arrangements should be publicly available.
- 4.53 The technical codes and subordinate documents currently provide a basic framework for the operation of the power system and electricity market, but are less comprehensive and prescriptive relative to industry practice.
- 4.54 Clearly documenting the role and functions of the System Control Group (imposed through the regulatory framework or by agreement with related parties) would make it more accountable for its actions against stated requirements, whether these are in the technical codes or in service level agreements with related parties.

Legal separation

4.55 Figure four shows a PWC structure where there is legal separation of regulated network and supervisory activities from the contestable related generation and retail

activities. This is a structure adopted in most NEM jurisdictions in the initial electricity market development phase.

Figure 4: Structure with legal separation of regulated network and supervisory activities

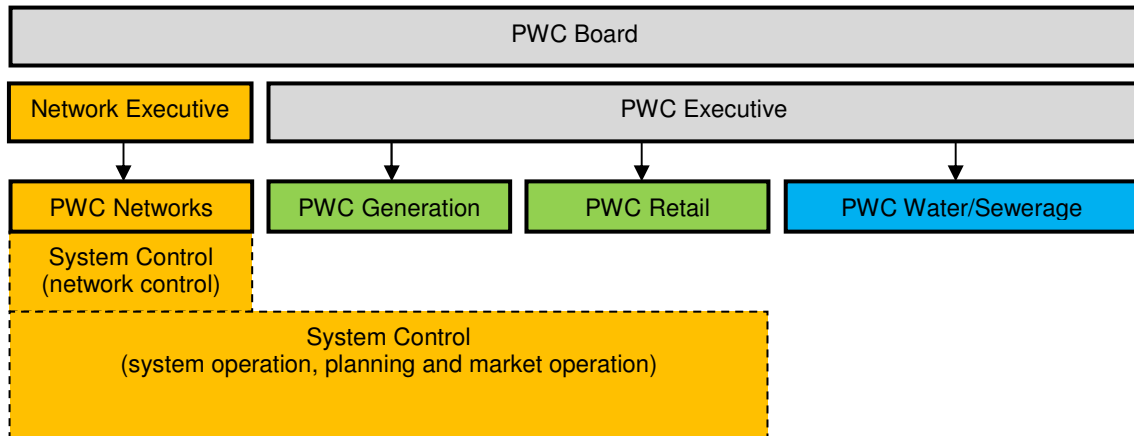

4.56 Legal separation would enhance confidence that supervisory activities were conducted separately to PWC's contestable generation and retail activities. This model would probably increase the profile of the System Control Group in PWC by making it the responsibility of a more focused management group and through increased visibility of System Control activities at Board level.

4.57 Legal separation would need to be supported by the clear documentation of the role and functions of the System Control Group (imposed through the regulatory framework or by agreement with related parties).

Ownership separation

4.58 Figure five shows a PWC structure where there is ownership separation of regulated network and supervisory activities from the contestable related generation and retail activities. This is a structure adopted in most NEM jurisdictions in more recent stages of electricity market development.

4.59 Most recently, the government owned network businesses in New South Wales and Queensland divested their retail activities.

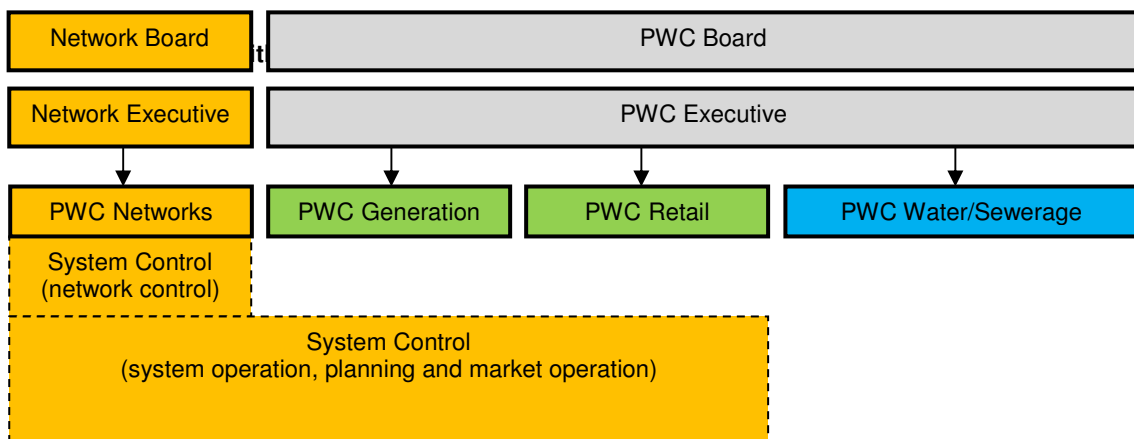

4.60 Ownership separation of regulated network (and supervisory) activities is the model adopted in the NEM and Western Australian SWIS. This model provides the greatest certainty and confidence that network and system management occur without being influenced by the interests of one or another related party.

Draft recommendation – allocating responsibility for supervisory and for-profit functions

4.61 In the Draft Report, the Commission considered that adopting the NEM approach of establishing a separate and independent system and market operator for the Territory would involve significant transaction costs, and would leave a separate system and market operator with the difficult task of acquiring the required expertise.

4.62 The Commission considered that the need for the supervisory functions to be performed independently could be balanced against the transaction costs of establishing a separate independent entity responsible for market and system operation by establishing clear lines of reporting and accountability for the System Control supervisory functions. The Commission recommended:

- establishing a clear set of detailed rules in the regulatory framework to identify what system and market operation tasks are to be undertaken by the System Control Group and what those tasks involve;
- defining in the regulatory framework the scope of a system planning function and clearly allocating responsibility for that function to the System Controller (or some other appropriate entity);
- strengthening ring-fencing arrangements to require that the nature of the relationship and interactions between each of the PWC business units including the System Control Group, PWC Networks, PWC Generation and PWC Retail business units, are clearly documented and available to system participants and other relevant parties; and
- making the System Controller directly accountable to the PWC Board for the performance of supervisory system and market operation and system planning activities.

4.63 The Commission contended that, depending on the relationship between the market and system operation and system planning functions of the System Controller and the network operation functions of PWC Networks, it could be appropriate to consider whether accountability for these supervisory and monopoly functions should all be separated from the accountability for the for-profit generation and retail functions to ensure a “level-playing-field” that supports the potential emergence of other for-profit electricity businesses in the Territory.

4.64 To enhance the visibility and importance of the System Control supervisory functions within PWC, the Commission recommended that the System Controller be directly accountable to the PWC Board for the performance of supervisory system and market operation and system planning activities. Network operation and control functions could be carried out by the System Control Group under a service provision agreement with PWC Networks.

4.65 The resulting reporting structure could look like figure 6.

Figure 6: Proposed System Controller and System Control reporting lines and accountability

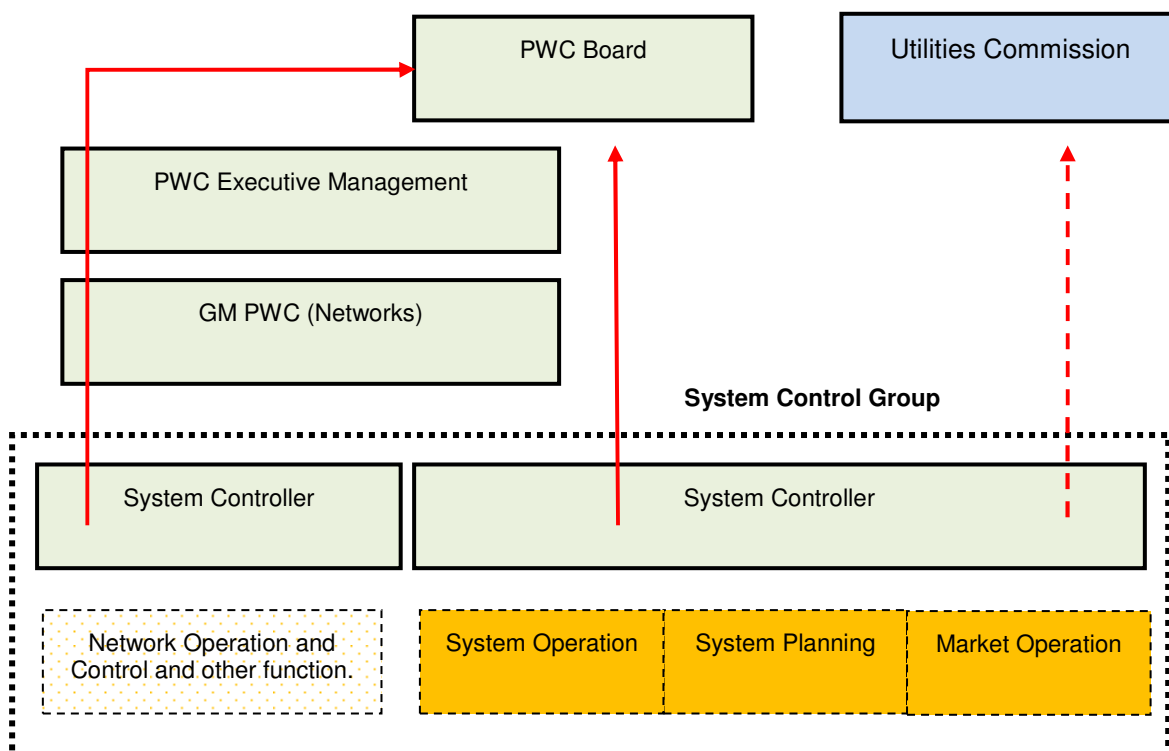

4.66 The Commission recommended that the Commission be responsible for oversight of compliance with the regulatory framework by the System Controller.

4.67 It also recommended that, in the medium to longer term, the issue of legal separation of the PWC Networks business unit be considered.

Views in submissions

4.68 PWC submitted that the System Control Group was once independent of PWC Networks. However, in order to address operational issues resulting from its dual function as System Controller and Network Controller, the System Control Group was placed within the Networks business unit. PWC advised that the System Control functions were ring-fenced from other PWC Networks activities.

4.69 PWC was concerned about the Commission's recommendation that the System Controller report directly to the Board. In PWC's opinion, the regulatory reporting by a business unit should be subject to review by both PWC's Managing Director and Board. Further, it argued that the level of independence for the System Controller sought by the Commission was achieved by the System Controller directly reporting to the Managing Director, which is in accordance with standard corporate governance arrangements and the *Government Owned Corporation Act*.

4.70 Moreover, PWC highlighted the fact that the System Control Group and Power Networks business unit had re-negotiated all Service Level Agreements (SLA) for non-System Control Licence delivery functions. Similarly an SLA had been developed between the System Control Group and PWC Generation. PWC proposed that the

System Controller's provision of services for its various activities be costed and recovered.

- 4.71 PWC expressed concern about the recommendation regarding the need to clearly document and make available to system participants the relationship and interactions between each of the PWC business units. PWC argued that the SLAs and Related Party Terms between PWC Retail and PWC Generation, and PWC Retail and PWC Networks should not be made publicly available as they contain information of a commercial nature.
- 4.72 PWC also expressed concern about the possibility of the transmission planning function being transferred from PWC Networks business unit to the System Controller. PWC considered that in the Territory context the segregation between distribution and transmission networks was inappropriate and the current arrangements were satisfactory.
- 4.73 PWC proposed that the System Controller have responsibility for preparing short, medium and long term adequacy reports which would signal potential supply-demand shortfalls, transmission constraints and system security issues.
- 4.74 PWC advised that a Power Technical Committee had been established within PWC to facilitate strategic coordination and planning of technical power matters.
- 4.75 Given the small size of the Territory system, ESAA did not support the idea of separating the System Controller from PWC as it would create duplication of roles and functions, and add unnecessary costs. The ring-fencing arrangements in place appeared to be sufficient to ensure appropriate levels of independence.
- 4.76 QEnergy expressed the view that the Commission should concern itself with the System Controller's lack of independence and the signal this sends to investors.
- 4.77 QEnergy was supportive of the Commission's recommendations in relation to allocating responsibility for supervisory and not-for-profit functions.

Response to views in submissions and further analysis

- 4.78 The Commission considers that, under the current arrangements, the System Controller's focus appears to be more directed towards the network control functions, resulting in its market and system monitoring role being diminished. The Commission is of the view that the System Controller (in its system and market supervisory role) should be seen to provide a service to not only PWC but also to the market as an independent expert.
- 4.79 The Commission considers that the current arrangements do not provide sufficient confidence amongst prospective new market participants considering entering the Territory market that they would be treated by the System Controller on the same basis as PWC's business units. As a result, the Commission recommends that the System Controller retains its existing reporting line for administrative purposes but should be able to report directly to the Board on system matters. To be clear, the Commission does not propose any structural change to the System Controller within PWC Networks. The Commission recommends that the System Controller's access to the Board be limited to its market and system supervisory role.
- 4.80 The Commission does not doubt the independence of the PWC Managing Director. The Commission is concerned that having the same reporting line available to the
-

System Controller for network service provision and its supervisory functions may erode the delineation between the System Controller's dual functions, resulting in a potential loss of independence.

- 4.81 Given that competition at the generation level is at this stage purely prospective, the Commission's recommendation is considered pragmatic whilst providing some degree of assurance to the market that the System Controller (in its market and system supervisory activities) is able to exercise its statutory functions independently and without any level of actual or perceived interference.⁴²
- 4.82 In response to ESAA, the Commission notes that while it considered the separation of the System Controller as an option, it was not recommended in the Draft Report as it would require significant transaction costs.
- 4.83 The Commission supports PWC's initiative to have the provision of non-supervisory services accurately identified, defined and priced using SLAs. However, the Commission notes that the Ring-fencing Code does not extend the Commission's oversight to the various functions performed within the System Control Group. Subsequently, the Commission is of the view that strengthening the ring-fencing arrangements between system and market supervisory activities and network control operations might be required.
- 4.84 The Commission does not propose to release the SLAs and Related Party Terms between PWC Retail and Generation, and PWC Retail and PWC Networks.⁴³ The Commission acknowledges that these documents may contain commercially sensitive information. The Commission's intention is limited to making available information on System Control services and costs relating to its market and system activities to ensure appropriate levels of accountability and transparency, so that the System Controller is held responsible for its performance and outcomes.
- 4.85 Finally, the Commission considers that system planning functions allocated to the System Controller would give it a greater focus in relation to the strategic planning and design of transmission and generation. Evans and Peck⁴⁴ in their supporting analysis for the 2009-10 Power System Review noted the weakness of the current design of the Darwin-Katherine system with most of the generation assets located on Channel Island and only one transmission corridor.

Final recommendation

- 4.86 The Commission does not propose to make further changes to its recommendations about allocating responsibility for supervisory functions and for-profit (operational) functions. The Commission recommends, however, that disclosure of information be limited to services and costs provided by the System Controller in relation to market and system operation activities, and system planning.

⁴² S.38 of the *Electricity Reform Act* requires the system controller to monitor and control the operation of the power system with a view to ensuring that the system operates reliably, safely and securely in accordance with technical code prepared by the system controller and approved by the Utilities Commission.

⁴³ The *Utilities Commission Act* stipulates that disclosure of information considered confidential cannot be made without the consent of the person who gave the information or to whom the information relates [s.26(2)(b)]

⁴⁴ The Commission engaged Evans & Peck in 2010 to assist the Commission in developing its annual Power System Review.

Supporting the independence of the System Controller

- 4.87 The System Controller is entitled to impose and recover charges relating to the operations of system control, with the schedule of charges approved by the Commission.⁴⁵
- 4.88 The Commission approved a \$0.01/kWh charge in June 2004, to apply from July 2004 for provision of system control services in the market systems.⁴⁶ The charge has remained at \$0.01/kWh since 2000. The Commission has no information about the specific services provided by the System Controller and the System Control Group, or their cost, but it is unlikely that the \$0.01/kWh would be sufficient to recover the cost of providing system control services. Changes to the system control charges are initiated by the System Controller submitting a proposal to vary the charges to the Commission for approval.
- 4.89 The Commission considers that the System Controller should be required to regularly assess the resources required to effectively undertake market and system operation and system planning functions, and use this information to calculate a proposed system control charge for the coming financial year (to be approved by the Commission).
- 4.90 This should give the System Controller a measure of financial and operational independence in the performance of the critical public interest system control functions, thereby guarding against the actual or perceived risk that the System Controller does not have the resources required to perform its tasks, and is not able to perform its tasks to the standard required to maintain a secure, reliable and safe electricity supply.
- 4.91 Effectively, the System Controller should be able to clearly demonstrate that they have the capability required to perform the critical public interest functions, and to clearly demonstrate that they have the resources required to obtain and maintain that capability.
- 4.92 The cost of any other activities or functions performed by the System Controller or the System Control Group should be recovered through separate arrangements. For example, the costs of network control activities should be recovered through the regulated charges approved by the Commission through the five yearly network price determination processes.

Draft recommendation – financial independence of system controller

- 4.93 In the Draft Report, the Commission recommended that the System Controller be required, on an annual basis, to:
- consult with system participants on the system control services to be provided in the coming financial year, the estimated cost of those services, and the proposed system control charges required to recover that cost; and
 - seek the Commission's approval for the proposed system control charges; and

⁴⁵ *Electricity Reform Act*, s39

⁴⁶ Utilities Commission, Determination: Approval of System Control Charges from July 2004, June 2004, http://www.nt.gov.au/nt/utilicom/s_docs/approv_instrum_sys_control_2004-05.pdf.

- account for expenditure of the revenues received from the system control charge in the previous financial year.

4.94 In assessing the amount of the system control charge, the System Controller should distinguish between the commercial functions of network control and the public interest functions of market and system operation. The system control charge should incorporate only those costs associated with public interest functions. The cost of any other activities or functions performed by the System Control Group should be recovered through separate arrangements.

Views in submissions

4.95 PWC re-iterated that its costs are separated between regulated and non-regulated activities and documented in the SLAs.

4.96 PWC was supportive of the Commission's recommendation to conduct an annual process to determine the System Controller's charges. It agreed that the current 0.1 cent/kWh charge under-recovers the total cost of System Control functions.

4.97 PWC's view was that this exercise would only be worthwhile if the System Control charge can be fully passed through to customers in the retail tariffs authorised by the Electricity Pricing Order.

4.98 QEnergy was supportive of the System Controller being financially independent. It also added that there was a role for the Commission in ensuring that cost transfer between PWC Retail, PWC Generation and System Control does not occur.

Response to views in submissions and further analysis

4.99 In its discussion of the allocation of responsibility for supervisory and for-profit functions set out above, the Commission advised that a strengthening of the ring-fencing arrangements was necessary to require that the nature of the relationship and interactions between each of the PWC business units are clearly documented and available to system participants and other relevant parties.

4.100 Following this strengthening of the Ring-fencing Code, the Commission intends to review the PWC cost allocation methodology and the SLAs between the System Controller and PWC Networks to ensure that there is no cost transfer and charges are cost reflective.

4.101 The Commission does not agree with PWC's view that the Commission's recommendation about the financial independence of the System Controller is only meaningful if PWC is able to pass through its costs by way of the Electricity Pricing Order. System Control charges are not limited to those customers on regulated tariffs as they are also charged to those customers on negotiated tariffs. Moreover, a more accurate understanding of the resources required by PWC to perform its various activities would support PWC's case in its attempt to recover all its costs. The most appropriate mechanism by which these costs can be recovered (Electricity Pricing Order or CSO) is a matter for the Government to decide.

Final recommendation

4.102 The Commission does not propose to make further changes to its recommendations about supporting the financial independence of the System Controller.

CHAPTER 5

Implementation considerations

- 5.1 The terms of reference request the Commission to recommend a course of action and provide detailed plans for implementation of that recommendation.
- 5.2 Implementation considerations include:
- options for implementing the Commission's recommendations; and
 - potential future allocation of roles and functions.
- 5.3 Implementation of the Commission's recommendations would involve development of an implementation program and project plan by an implementation group comprising representatives of industry, policy and regulatory entities. Terms of reference for the implementation group are being progressed by Northern Territory Treasury in conjunction with the Commission.
- 5.4 The recommendations involve a significant effort to develop new regulatory requirements. The experience and regulatory arrangements of the NEM provide a sound starting point.

Options for implementing the Commission's recommendations

- 5.5 The Commission's recommendations can be implemented through the development of an Electricity Industry Code, providing the opportunity to:
- clearly document the requirements and expectations of system and market operation functions;
 - establish responsibility for oversight of compliance with market and system operation functions, documenting the respective roles of the Commission and System Controller. This can occur through a statement of approach developed jointly by the Commission and System Controller (in consultation with system participants), or through drafting of the Electricity Industry Code;
 - establish a comprehensive rule change process that separates responsibility for rule-making and operation functions. This will also require amendment to the Electricity Networks (Third Party Access) Code and the *Electricity Reform Act* (and potentially other legislation) to remove sole responsibility for administering the Network Connection Technical Code and System Control Technical Code from PWC Networks and the System Controller;
 - separating responsibility for supervisory and for-profit activities by amendment of the Ring-Fencing Code, the development of new regulatory arrangements, and changes to PWC's corporate governance arrangements; and
 - the *Electricity Reform Act* establishes the ability of the System Controller to assess and levy a system control charge.
-

Allocation of roles and functions

5.6 The nature of the functions associated with the allocation of responsibilities for effective management of the electricity supply chain, including system and market operation and system planning functions is discussed in a separate Report for the Review of Electricity System Planning, Monitoring and Reporting.

Proposed allocation of key roles

5.7 Based on the recommendations of this paper, Table 5.1 provides a proposed allocation of key roles required for the effective management of the electricity supply chain, and the delivery of electricity according to the requirements of the regulatory bargain.

Table 5.1: Proposed allocation of key electricity sector roles

Role/functions	Responsible entity
Rule-making	Treasury and Utilities Commission, subject to a defined rule-making process.
Market operation	PWC Networks / System Controller. The limited market operation role is currently undertaken by the PWC corporate services (strategy and corporate affairs) area.
System operation/planning	System Controller.
Network operation	The System Controller could perform network operation functions under an agreement for services with PWC Networks.
Compliance monitoring	System Controller – oversight of compliance with technical codes. Utilities Commission – oversight of compliance with regulatory instruments (including compliance by System Controller).

Proposed reporting arrangements and responsibility

5.8 The Final Report for the Review of System Planning, Monitoring and Reporting recommends development of new planning, monitoring and reporting arrangements for the Territory, but does not discuss which entity might be responsible for what task. Based on the recommendations of that Report and this paper, Table 5.2 outlines the possible future planning, monitoring and reporting arrangements, and the possible allocation of responsibility for the associated activities.

Table 5.2: Proposed allocation of planning, monitoring and reporting functions

Role/functions	Responsible entity
System planning - Demand forecasts - System adequacy assessment - Investment projects - Asset condition	The Commission is currently responsible for producing system planning information through the annual power system review. This activity is more appropriately undertaken by the System Controller. Transferring this responsibility would require a high degree of confidence in the independence of the System Controller from the commercial imperatives of PWC.
	System planning information could be reported through: - A statement of opportunities style document could present longer term investment related planning information.

Role/functions	Responsible entity
	<ul style="list-style-type: none"> - A projected assessment of system adequacy document could present shorter term operations related planning information.
Network planning <ul style="list-style-type: none"> - Demand forecasts - Network adequacy assessment - Investment projects - Asset condition 	The Commission currently produces some limited network planning information through the annual power system review. This activity is more appropriately undertaken by PWC Networks. Network planning information could be reported through an annual network planning and management report.
Performance reporting <ul style="list-style-type: none"> - Generation and network reliability performance - Network and retail customer service 	System participants have been required to report reliability and service performance information under the Electricity Standards of Service Code. The Commission has made this information public. Reliability and service performance outcomes could be reported by the Commission through an annual Performance Report. The focus of the report would be to provide information about the levels of reliability and service performance achieved by system participants relative to performance targets and relevant benchmarks.
System and market data <ul style="list-style-type: none"> - Market and system statistics - System participant compliance - Power system incidents 	The Commission produces some system and market data through the Commission's Annual Report and the power system review. System and Market information could be reported by the Commission through an annual System and Market Report. The focus of the report would be to provide information about the health of the system and market, including by advising on retail and wholesale market conduct.

Views in submissions

- 5.9 PWC does not consider that the need for legislative change or substantive change to regulatory institutions and arrangements has been established by the Commission. Moreover, the Commission has not considered the time, costs and effort associated with implementing its proposed recommendations.
- 5.10 PWC acknowledges that a number of straightforward changes to the present accountabilities and reporting have been accepted by PWC. These changes could be developed over a much shorter time frame.

Response to views in submissions and further analysis

- 5.11 The Commission accepts that it is likely that there might be some up-front costs associated with its recommendations. However, the Commission considers that these costs will significantly decline over time as PWC develops capacity and systems to meet its obligations. It would be expected, however, that these costs will be outweighed by the derived benefits associated with the reforms.

- 5.12 The Commission believes that the arrangements in the NEM provide an important model for the Territory regulatory framework, but the model must be tailored to the circumstances of the Territory. Furthermore, this model is considered to be consistent with the Government's commitment to the National Competition Policy.
- 5.13 Following the Government's decisions regarding the Commission's recommendations, a working group comprising Treasury, the Commission and relevant industry representatives would be established to determine the most appropriate course and timeframe for implementing the reform actions.
-

APPENDIX A

Summary of functions

System operation involves:⁴⁷

- generation dispatch – scheduling which generators are producing electricity, and are available in reserve so that generation is sufficient to meet demand;
- determining transmission flow paths – scheduling transmission line availability so that transmission capacity is sufficient to efficiently deliver energy to customers;
- managing generation and transmission load shedding;
- developing and maintaining operating procedures for the system. These are the rules followed by the system operator, generators and TNSP;
- technical compliance monitoring – confirming generators meet defined operating and performance standards;
- incident investigation – analysis, investigation and reporting on the cause and response to system incidents; and
- reporting – providing information to electricity businesses on system operation and performance, such as a short term projected assessment of system adequacy.

System operation is supported by the **network control** activities of the TNSP and DNSP. The day to day management of network infrastructure includes:

- network switching, which requires coordination between the system operator, TNSP and DNSP to ensure line capacity is sufficient to meet demand;
- incident analysis – TNSPs and DNSPs will collect information on all outages to inform operating and planning activities. Incidents may be investigated by the system operator;
- undertaking connection studies and commissioning planning – assessing the implications for security and reliability of new connections to the network;
- developing and maintaining operational diagrams of the network design and operating status;
- outage management – coordination of planned outages; and
- emergency management.

⁴⁷ This list is informed by the rules for the national electricity market and the functions of the Australian Energy Market Operator.

Market operation involves the administration of the interactions of electricity industry participants that determine the price and quantity of electricity delivered into the distribution network. Key activities include:⁴⁸

- administration of the wholesale exchange for electricity. In the NEM the wholesale exchange supports system operation because the spot price determines the generation dispatch order;
- administration of credit support arrangements related to the trading of energy between generators and retailers;
- administration of ancillary services, including procurement; and
- participant registration – authorising the operation of generators and other market participants in the market.

System planning underpins system operation and market operation by identifying the electricity supply infrastructure investments needed to achieve the expected price and reliability of supply levels. The Commission examines system planning arrangements in the Review of Electricity System Planning, Monitoring and Reporting.⁴⁹ Key activities include:

- assessment of the technical parameters for the system (the technical envelope) relative to actual and expected performance outcomes;
- security and adequacy analysis – is the power system able to meet security and reliability standards. Adequacy analysis includes demand forecasting, and relies on knowledge of asset condition; and
- reporting on the actual and expected security and adequacy of the power system in the medium and long terms, such as through a statement of opportunities, medium term projected assessment of system adequacy and transmission development planning.
-

⁴⁸ This list is informed by the rules for the national electricity market and the functions of the Australian Energy Market Operator.

⁴⁹ Refer Utilities Commission website www.utilicom.nt.gov.au for the papers released as part of the Review of Electricity System Planning, Monitoring and Reporting.
